

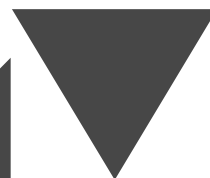

GRAM

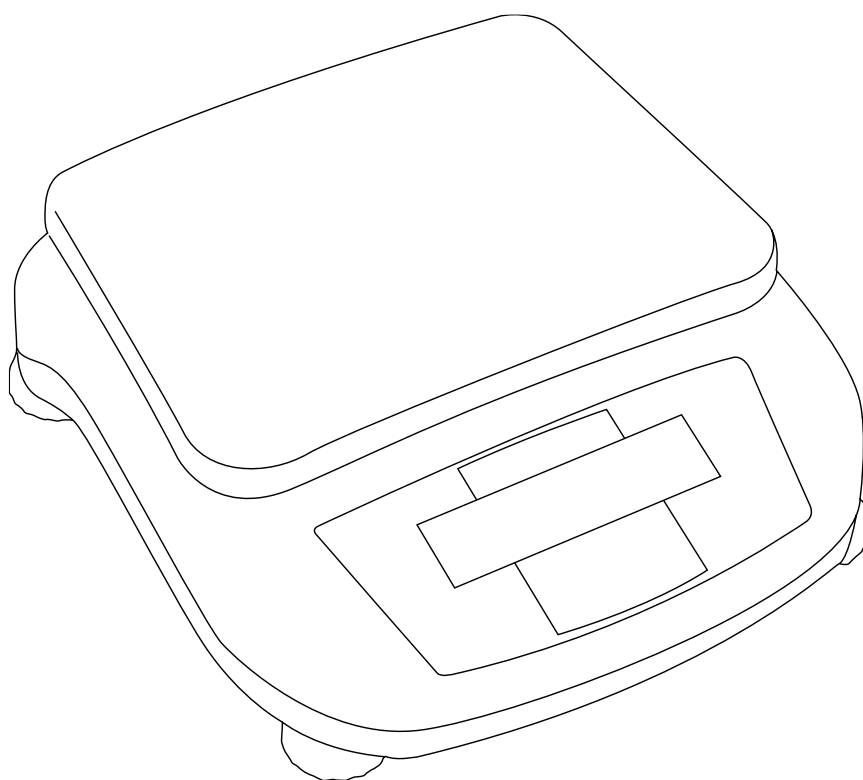

SERIE
EH



USER MANUAL

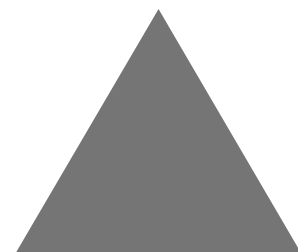

INDEX

Outline	3
Specifications	3
Before weighing	4
Main body	4
Name and function of the components	4
Choosing the installation site	5
Precautions on use	5
Operation keys	6
Unpacking and delivery inspection	6
Turning the power on	6
Warming up	6
Using the balance	7
Switching units	7
Performing span calibration	8

ENGLISH

OUTLINE

Thank you for purchasing EH series electronic balance. The EH models are high performance electronic balances that we confidently recommend based on 20 years of precision balance manufacture. While there models are of course capable of fast and accurate weighing, the EH models all work on high precision strain gauge load cell which implements high speed stabilization and high reliability. The EH series balances also feature operation keys, improving operating convenience and making the balances easier to use.

These balances also feature a variety of other functions that make it more convenient for customers to use for their own applications, including the Window Direct communication function, which enables measuring results to be transferred to a PC without installing any software.

To ensure that you can make full use of the performance and function of your EH series balances, read this instruction manual carefully and use the balance correctly in accordance with the directions in the manual. When you have finished reading the manual, keep it in a safe place together with the balance so that you can refer to it at any time.

EH series precision balance work on high precision strain gauge load cell which implements high speed stabilization and high reliability.

SPECIFICATIONS

Model No. (EH)	500	1000	2000
Máx. Capacity (g)	500	1000	2000
Tare Range (g)	0-500	0-1000	0-2000
Readability	0.01g		
Pan size (mm)	133x182mm		
Dimensions (LxWxH)	280x180x80mm		
Power supply	AC 110-120V/220-240V		

Model No. (EH)	3000	5000
Máx. Capacity (g)	3000	5000
Tare Range (g)	0-3000	0-5000
Readability	0.1g	
Pan size (mm)	143x192mm	
Dimensions (LxWxH)	280x180x80mm	
Power supply	AC 110-120V/220-240V	

Operating Temperature Range: 5-35 °C / Moisture: 50-85%.

BEFORE WEIGHING

Main body

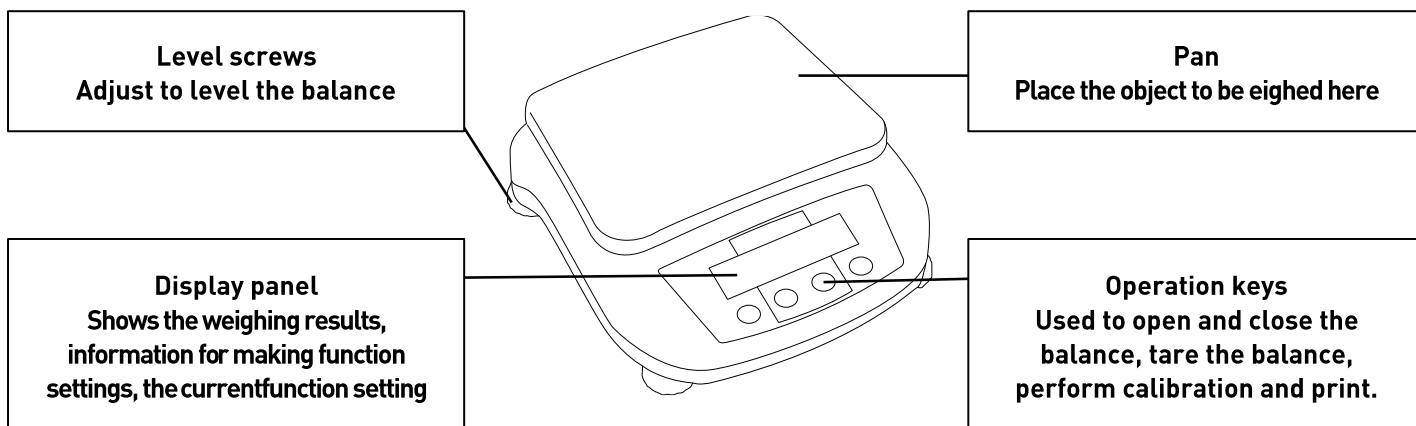

Name and function of the components

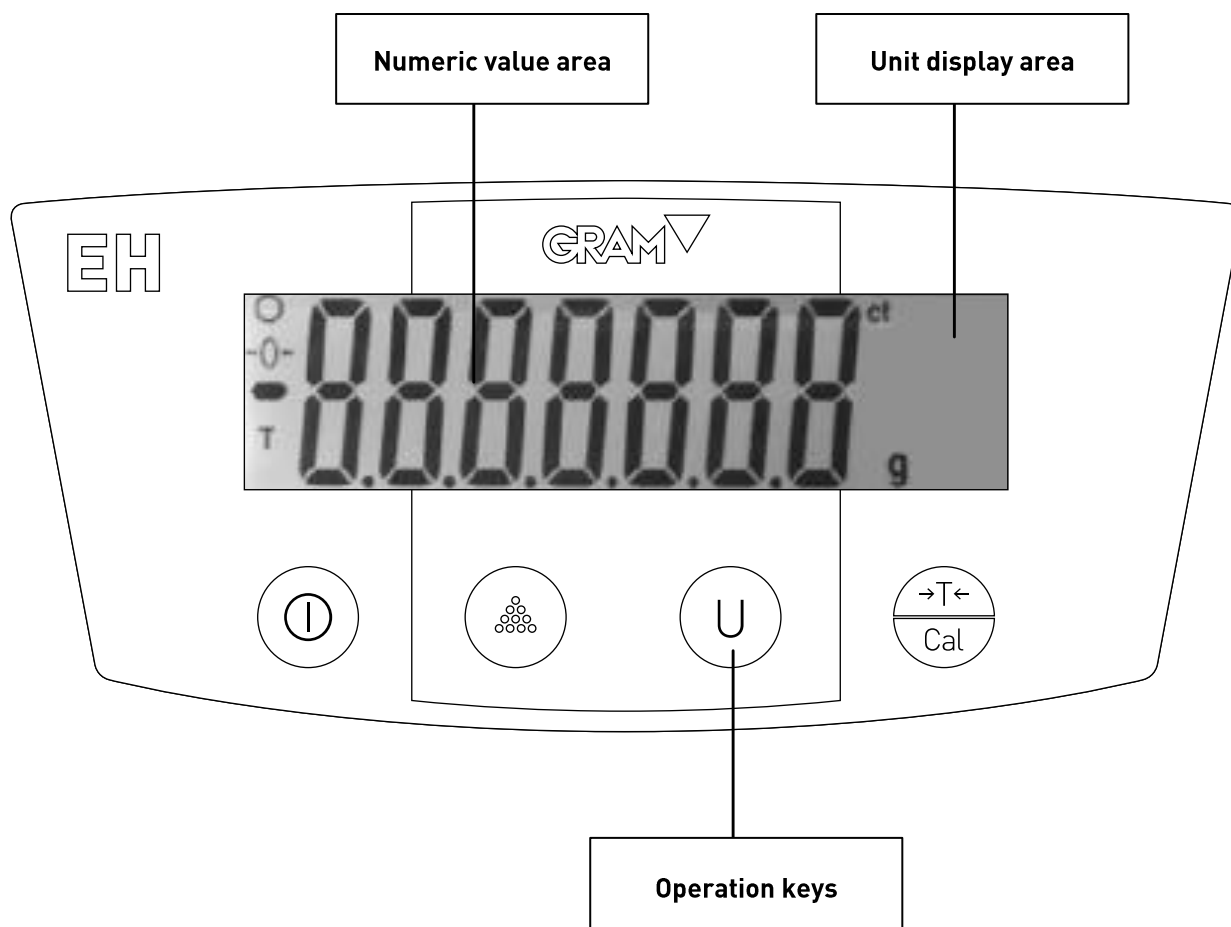

Choosing the installation site

The measuring performance of the balance is greatly influenced by the environment where it is installed.

Observe the following points to ensure safe and accurate weighing.

PRECAUTIONS ON USE



Prohibitions

Avoid locations where the balance will be exposed to any of the following.

- Air flow from an air conditioner, ventilator, door or window
- Extreme temperature changes
- Vibration from surroundings or nearby equipment

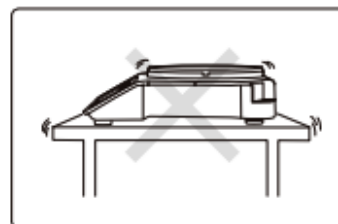
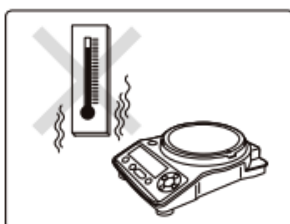
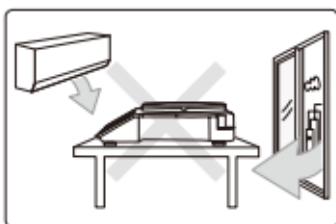

- Direct sunlight
- Dust, electromagnetic waves or a magnetic field

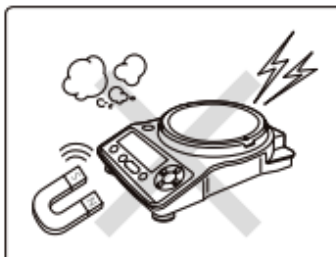
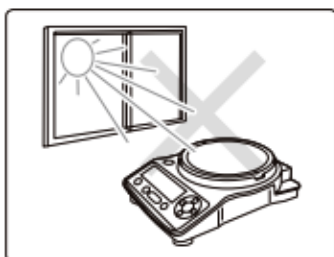





Instructions

Install the balance on a strong and stable flat table or floor.

Placing the balance in an unstable site could lead to injury or trouble with the balance. When selecting the installation site, take into account the combined weight of the balance and the item to be weighed.

OPERATION KEYS

Key	During Weighing	
	Press once and Release	Press and hold for a while
	Turn on or turn off the balance	—
	Select the counting function	—
	Tare the balance(setting it to zero)	Performs calibration
	Select the unit	—

Unpacking and delivery inspection

Check that all of the items indicated below are included in the package, and that nothing has been damaged.

1. Main Body.
2. Pan.
3. Introduction Manual.
4. Adapter.

Turning the power on

1. Insert the plug of the Power Cord into the DC IN connector on the back of the balance.
2. Connect the Power Cord to the power outlet.
3. Press “ON”.

The display will automatically go through the changes indicated below.

Warming up

Before performing span calibration on the balance or measuring its accuracy, you must ensure that it is in a stable state.

When stabilizing the balance, it is important that its temperature is stable.

Putting the balance in weighing mode and leave it with the power on for at least half an hour in advance of calibration.

This is called “warming up”.

Battery Use Button

To activate battery use, move the button located on the bottom of the scale to the position , as specified in the following diagram:

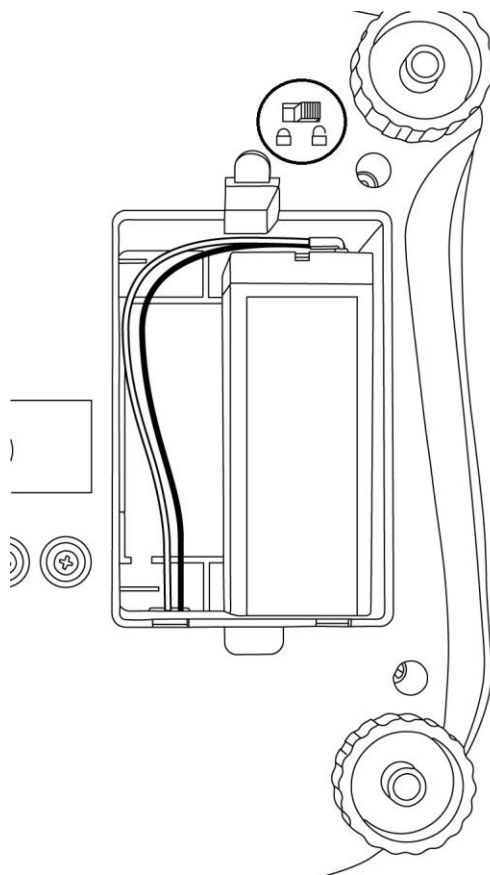

Using the balance

1. Enter the weighing mode.
2. Place a container on the pan.
3. Once the display has stabilized, press “zero/tare”.
 - 3.1. The indication changes to zero.
4. Insert the sample into the container.
5. When the display has stabilized, (the stability mark) lights up, read the display.

Switching units

You can display different units from among those set to be available.

1. press “UNIT” in the weighing mode.
Repeatedly pressing this key will cycle you through the registered units.

PERFORMING SPAN CALIBRATION

Always perform span calibration for a balance after moving it. Weights are required for external calibration balances.

Before performing span calibration, warm up the balance in advance.

Also, carry out the adjustment at a location where there are few people moving around and there is no air flow or vibration.

1. Press "CAL".

The weight value will flash.

The calibration record is being output. When the output has finished, span calibration will start automatically.

2. Place the calibration weight on the pan.

Wait until the flashing weight value display changes to a steady 500.00.

3. Take the weight off the pan.

"0.00" will be displayed and the balance will return to the weighing mode.

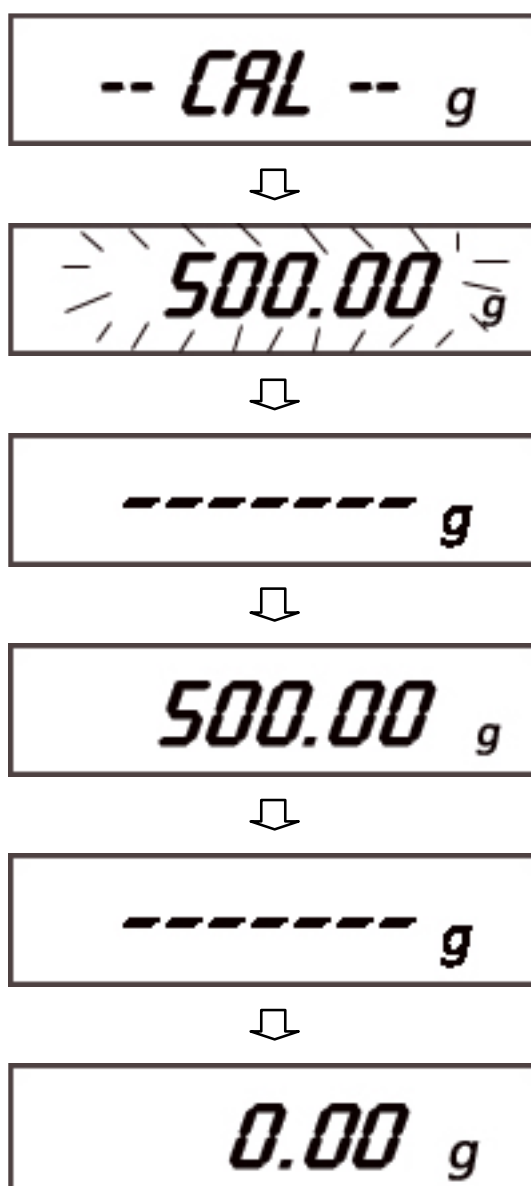



Gram Precision S.L.

Travesía Industrial, 11 · 08907 Hospitalet de Llobregat · Barcelona (Spain)

Tel. +34 902 208 000 · +34 93 300 33 32

Fax +34 93 300 66 98

comercial@gram.es

www.gram-group.com